



General
COMPONENTS



THE
LYNX
SERIES 

No-idle

AIR CONDITIONER

Introducing The Lynx Series.

Quiet and efficient AC with new high-tech variable speed compressor and low-noise fans.

Wireless remote and segment LCD with touch controls.

Check out other GC products at:

ridewithcomfort.com

MANUAL

models 1200 / 1200R
1500 / 1500R



4800 BTU
6000 BTU



12V
24V

TABLE OF CONTENTS

PREFACE	2
1. PRODUCT INFORMATION	3
1.1 Ordering Information	3
1.2 Areas of Application	3
1.3 Technical Specifications.....	4
1.4 Product Features	5
2. PRINCIPLE OF OPERATION.....	6
2.1 Electrical Diagram.....	6
2.2 Plumbing Diagram	7
3. INSTALLATION AND COMMISSIONING	8
3.1 Before the Install	8
3.2 Installation.....	10
3.2.1 Mounting the Unit.....	12
3.2.2 Making electrical connection	15
3.2.3 Commissioning	16
4. TROUBLESHOOTING	17
4.1 Troubleshooting of Common Problems	17
5. OPERATING INSTRUCTIONS.....	18
6. MAINTENANCE	20
7. PARTS LIST	21

PREFACE

Thank you for purchasing Lynx No-idle DC rooftop air conditioner. This service manual describes installation and operation procedures, maintenance recommendations and troubleshooting tips. Please read carefully before using the product to enjoy your cool comfort in a safe and efficient manner.

1. PRODUCT INFORMATION

1.1 Ordering Information

SKU #	DESCRIPTION
	12VDC 1400W 4800BTU, ROOFTOP, COOLING ONLY
	12VDC 1400W 4800BTU, ROOFTOP, HEAT AND COOL
	24VDC 1750W 6000BTU, ROOFTOP, COOLING ONLY
	24VDC 1750W 6000BTU, ROOFTOP, HEAT AND COOL

1.2 Areas of Application

Lynx series rooftop air conditioner is designed for use in a wide variety of automotive applications, such as mobile homes and RV's, utility vehicles, ambulance, construction vehicles, cargo trucks and heavy-duty equipment.

When connected to an APU (auxiliary power unit) it allows to maintain comfort inside vehicle for extended periods of time without need of idling the engine.



MARINE



HEAVY-DUTY



RV

1.3 Technical Specifications

Specification	Model			
	1200	1200R	1500	1500R
Electrical Characteristics				
Rated Voltage, V	12	12	24	24
Rated Current, A	50	50	33	33
Rated Power, W	600	600	790	790
Cooling Characteristics				
Air Flow, M ³ /hr	350	350	400	400
Cooling Capacity, W	1400	1400	1750	1750
Cooling Capacity, BTU	4800	4800	6000	6000
EER W/W	2.34	2.34	2.22	2.22
Heating Characteristics				
Heating Capacity, W	–	1400	–	1750
Heating Capacity, BTU	–	4800	–	6000
COP W/W	–	2.4	–	2.35
Weight and Dimensions				
Unit Weight	28.5kg	28.5kg	28.5kg	28.5kg
Shipping Weight	34kg	34kg	35kg	35kg
Unit Dimensions	70*58*26cm 23**27**10"	70*58*26cm 23**27**10"	70*58*26cm 23**27**10"	70*58*26cm 23**27**10"
Shipping Dimensions	27**32**15"	27**32**15"	27**32**15"	27**32**15"

1.4 Product Features

Lynx series rooftop air conditioner can provide up to 8 hours of no-idle cooling with standard capacity APU, and delivers high cooling performance, ultra-low vibration and noise and high energy efficiency thanks to the following features:

- Variable speed compressor allows proportional cooling, while reducing noise and increasing efficiency. Short-cycling of compressor is no longer a concern;
- Unit uses industry-standard R-134A eco-friendly refrigerant;
- Low-noise condenser and evaporator fans run very quiet;
- Unit designed for fast and adequate reaction to temperature changes for increased comfort;
- Wireless remote and on-unit segment LCD and touch panel provided for operator's convenience.

2. PRINCIPLE OF OPERATION

2.1 Electrical Diagram

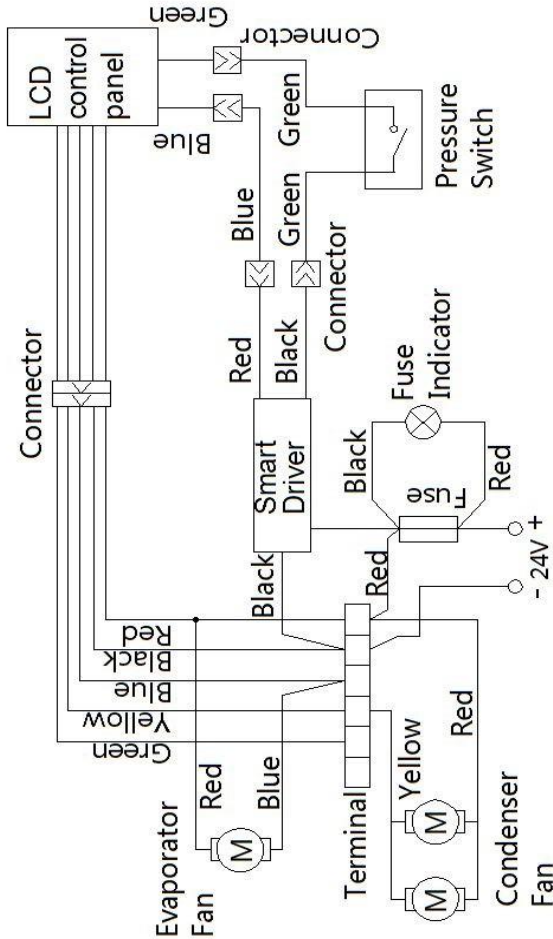

2.2 Plumbing Diagram

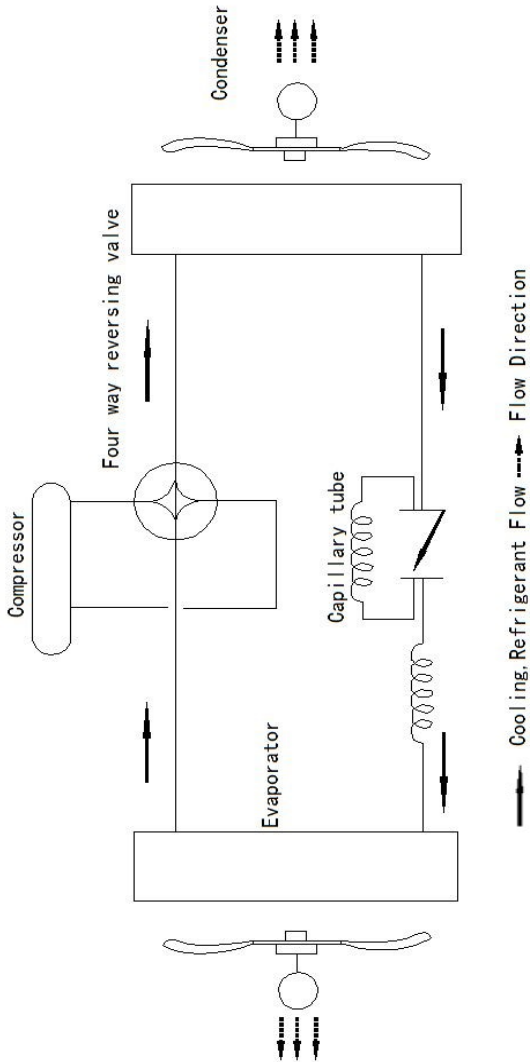

3. INSTALLATION AND COMMISSIONING

3.1 Before the Install

Ease of install is one of the main pros of Lynx series AC. All refrigerant-carrying components of this kit are factory-tested for leaks and proven safe. Every kit comes pre-charged with refrigerant and contains all parts and hardware required for installation:

- AC assembly (rooftop unit)
- Indoor panel
- Mounting hardware
- Remote control
- Mounting plate and sleeve



Unpack, identify and inspect all components of the kit before commencing install.

WARNING

- ⚠ **Do not install this product in places where combustible gas or vapor may be present.**
- ⚠ **Do not shorten, extend or in other ways modify factory-provided refrigerant-carrying parts. Doing so will void the warranty and will cause equipment malfunctions.**
- ⚠ **Do not attempt to repair damaged refrigerant lines.**
- ⚠ **Refer to Electrical Code regulations when altering main power feed. Special consideration should be made to protect power conductors with properly sized fuse or circuit breaker at the point of connection to the APU. The AC unit itself has a built-in overcurrent protection and does not require any special considerations.**

3.2 Installation

Before mounting the rooftop unit, following points should be considered:

- Unit placement: fans facing back of the vehicle.
- Roof composition: wiring, plumbing, moving (sun roof) or load-bearing parts (cross-beams) that cannot be disturbed or obstructed.
- Unit should be installed horizontally, $\pm 8^\circ$ max., onto a flat, even surface.
- Indoor panel location, ideally, should be in the middle of cooled area.
- Ease of access: Unit should be easily accessible for service and maintenance.

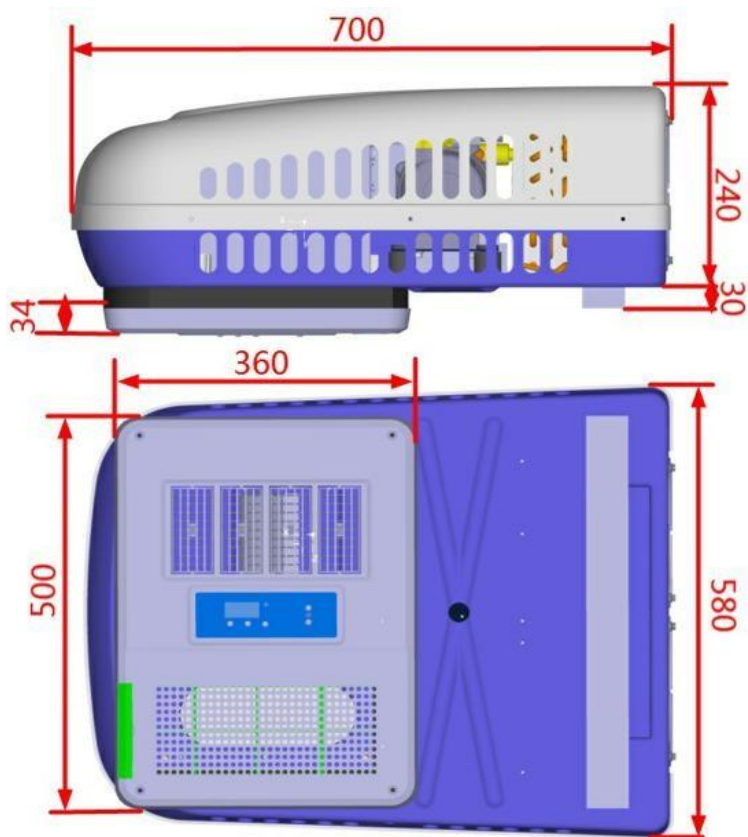

3.2.1 Mounting the Unit

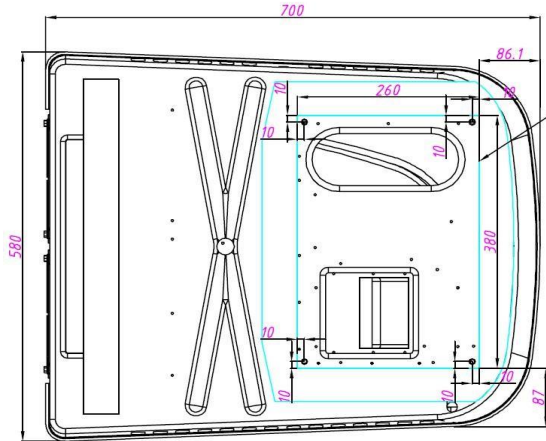

1. Make a 380*260mm (15" * 10 1/4") cut-out in the desired location. Keep in mind that the cut-out is not in the middle of the AC unit, but is closer to the front of the vehicle:

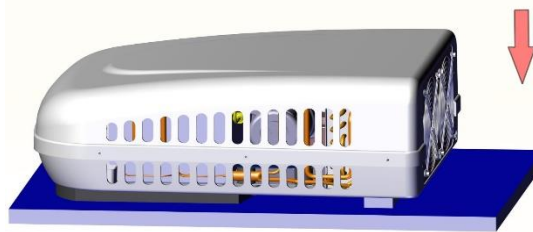

← Front of the vehicle

2. Place the rooftop unit into position on top of the vehicle.

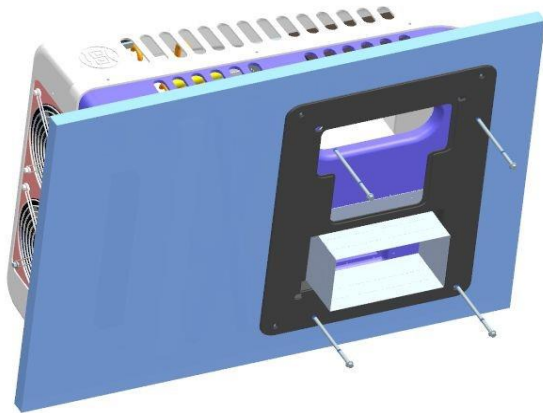
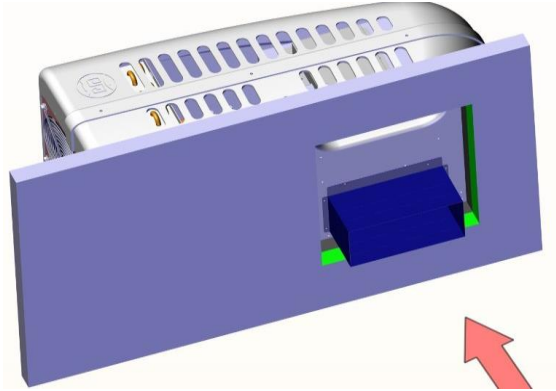

3. Place flange on the inside and secure it with the bolts provided with the kit. Install the sleeve, if provided.

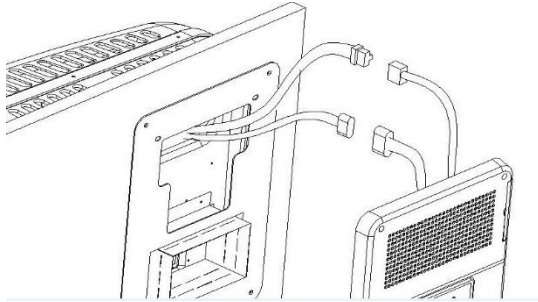

4. Make electrical connection between the rooftop unit and indoor panel, then secure indoor panel to the flange with screws provided with the kit.



3.2.2 Making electrical connection

Connect positive and negative supply conductors to the APU. Total length of supply conductors should not exceed 5 meters (15 feet). Adequate support, mechanical and thermal protection should be provided to prevent friction and consequent insulation damage. Supply conductors should be protected with properly sized fuse or circuit breaker.

WARNING



- ⚠ Compressor is pre-charged with the right amounts of oil and refrigerant. Do not overfill.**
- ⚠ When adding refrigerant to the system, do not open the high-pressure manual valve, otherwise, the AC system would force the refrigerant into refrigerant container, and push the lubricating oil out, which will damage the system.**
- ⚠ When adding the lubrication oil to the compressor, only 350ml of POE RB68EP oil should be used. Please use only designated oil type. Mixture of different brands of lubrication oil will form precipitates, which will affect compressor lubrication.**

3.2.3 Commissioning

After the power is applied, simply run the unit as described in operating instructions. Look for abnormal noise, vibration or smell.

Let the unit run continuously at full power for at least twenty minutes. If no faults came up on the operator panel and the unit runs smooth – your installation is complete.

4. TROUBLESHOOTING

All work on the unit should be carried out by qualified and certified individual. If unit is not performing as expected, or display is showing a fault code – stop using the unit and refer to a professional. Do not perform any work without proper tools and training.

4.1 Troubleshooting of Common Problems

Symptom	Cause	Remedy
The compressor does not start or starts and stops frequently (short cycles)	The voltage is too high or low	Bring voltage to specified voltage range
	Power supply cable is undersized	Use proper gauge supply lines
	Incorrect temperature setting	Set temperature
	Refrigerant leak in system	Repair leak and add refrigerant
Poor cooling performance	Condenser and/or evaporator coils are clogged with dust Fans or airways obstructed	Clean filter and condenser Inspect the heating exchange of the condenser
The air conditioner does not power on	The fuse in open Voltage too low The wiring or plug-in connector is not connected well	Check and replace the fuse Provide adequate voltage Verify, reseal connections
Air conditioner drains the battery faster than expected	Battery depleted or capacity is too low	Repair or upgrade the battery

5. OPERATING INSTRUCTIONS

Operation of the unit is very simple and self-explanatory. It could be done via remote control or control panel on the unit itself. When a button pressed on the remote, the unit should beep once to acknowledge the command.

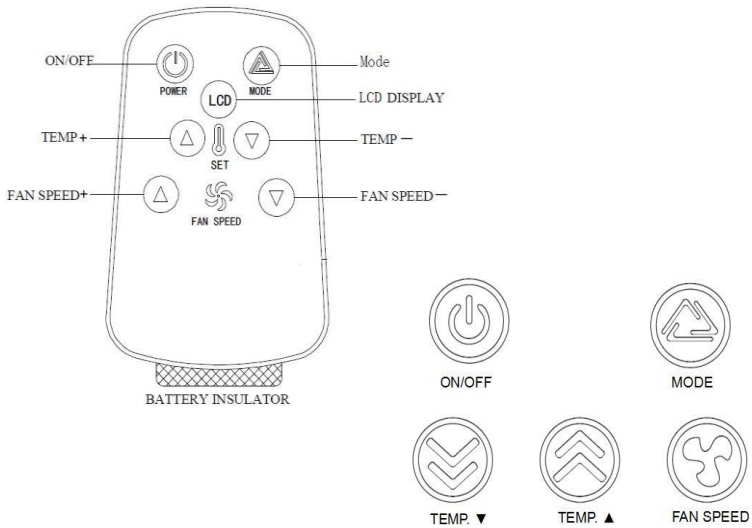

- Use **ON/OFF** power button to turn the unit on and off.
- Use **MODE** button to switch between **Cooling**, **Fan** and **Auto** modes.
- Use **TEMP** ▲(up) ▼(down) buttons to adjust desired setpoint.
- Use **FAN SPEED** buttons to adjust indoor fan speed.
- Use **LCD** button to toggle between °C and °F display.



The unit should not be used at temperatures below +5°C (41°F) or above +43°C (110°F).

6. MAINTENANCE

Regular yearly maintenance of the unit should be carried out before warm season and should consist of the following items:

- ✓ Clean condensate drain hose;
- ✓ Clean condenser coil and fan from dust;
- ✓ Clean evaporator coil and fan from dust;
- ✓ Clean evaporator condensate drain from clogs;
- ✓ Inspect screws and bolts holding the units, make sure they are tight;
- ✓ Inspect wiring for frays;
- ✓ Inspect refrigerant lines and insulation for damage.



Do not use pressure wash or sharp metal objects when cleaning evaporator and condenser coils, as this can cause fins to bend and reduce efficiency of the unit. Use compressed air, vacuum, soft brush to clean the coils, do not apply force.

7. PARTS LIST

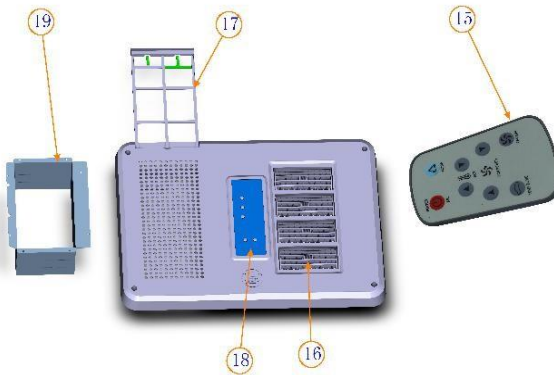
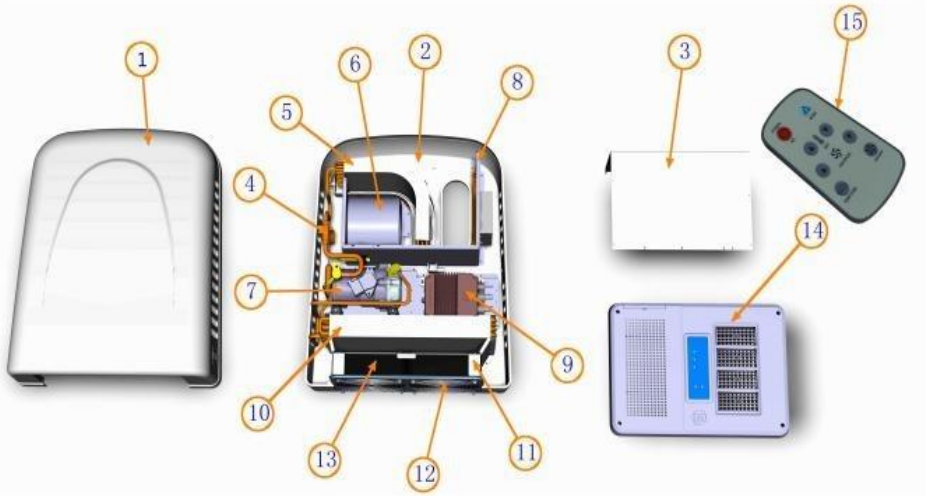

No.	Part name	SKU	Q'ty
1	Unit cover	GC1040	1
2	Tray	GC1041	1
3	Evaporator Cover	GC1042	1
4	Copper pipe	GC1043	3
5	Evaporator	GC1044	1
6	Evaporator Fan	GC1045	1
7	12/24VDC Rotary Compressor	GC1046	1
8	U-type plate	GC1047	1
9	Compressor driver	GC1048	1
10	Condenser unit	GC1049	1
11	Condenser bracket	GC1050	2
12	Fan grid guard	GC1051	2
13	Condenser fan	GC1052	2
14	Control panel	GC1053	1
15	Remote controller	GC1054	1
16	Indoor air grille	GC1055	4
17	Filter screen	GC1056	1
18	Controller	GC1057	1
19	Air duct (sleeve)	GC1058	1



203 – 1515 Broadway St Port Coquitlam, BC Canada, V3C 6M2
+1.800.517.7740 | +1.604.677.6210
info@generalcomponents.ca

June 2020