



No-idle

AIR CONDITIONER

FREE SHIPPING*
until May 31, 2020

Introducing **The Lynx Series.**

Quiet and efficient AC with new high-tech variable speed compressor and low-noise fans.

Comes with **wireless remote**, and segment LCD with touch controls.

Learn more:
ridewithcomfort.com

	
6800 BTU	12V
8800 BTU	24V

*Only for US and Canada.

Table of Contents

PREFACE	1
1. PRODUCT INFORMATION.....	2
1.1 Ordering Information.....	2
1.2 Areas of Application.....	2
1.3 Technical Specifications	2
1.4 Product Features.....	1
2. WORKING PRINCIPLE	2
2.1 Electrical Diagram	2
2.2 Plumbing Diagram.....	2
3. INSTALLATION AND COMMISSIONING	3
3.1 Before the install.....	3
3.2 Installation	4
3.2.1 Mounting the outdoor unit (condenser).....	4
3.2.2 Mounting the indoor unit (evaporator).....	5
3.2.3 Installing Refrigerant Lines.....	5
3.2.4 Wiring.....	6
3.2.5 Commissioning.....	6
4. TROUBLESHOOTING.....	7
4.1 Troubleshooting of common problems	7
4.2 Fault codes and descriptions	8
5. OPERATION	9
6. MAINTENANCE.....	10
7. PARTS LIST.....	11

PREFACE

Thank you for purchasing Lynx No-idle DC split type air conditioner. This service manual describes installation and operation procedures, maintenance recommendations and troubleshooting tips. Please read carefully before using the product to enjoy your cool comfort in a safe and efficient manner.

1. PRODUCT INFORMATION

1.1 Ordering Information

SKU #	DESCRIPTION
GC6180	24VDC 2600W 8800BTU SPLIT AIR CONDITIONER KIT
GC6181	12VDC 2000W 6800BTU SPLIT AIR CONDITIONER KIT

1.2 Areas of Application

Lynx series split type air conditioner is designed for use in a wide variety of automotive applications, such as utility vehicles, ambulance, armored vehicles, construction vehicles, cargo trucks and heavy-duty equipment. When connected to an APU (auxiliary power unit) it allows to maintain comfort inside vehicle for extended periods of time without need of idling the engine.

1.3 Technical Specifications

Parameter	12VDC Version	24VDC Version
Operating voltage range, V	11.5~15.5	12.5~32
Rated power, kW/BTU	2/6800	2.6/8800
Current rating, A	50	38
Current draw, A	25-70	10-45
Airflow, m3/hr	250	300
Setpoint range	16-32 °C	
Refrigerant type	610±20g R-134a	
Working pressure	0.4/1.8 Mpa	
Compressor type	3-phase variable speed, hermetic	
Compressor lubricating oil	RL68H(POE) 90-120ML	
Gross/Net weight, kg	Indoor unit(evaporator): 11 / 6 Outdoor unit (condenser): 32 / 24	
Dimensions(L*W*H), mm	Indoor unit(evaporator): 540×362×185 Outdoor unit (condenser): 682× 465×192	

1.4 Product Features

Lynx series split air conditioner can provide up to 8 hours of no-idle cooling with standard APU, and delivers high cooling performance, ultra-low vibration and noise and high energy efficiency thanks to the following features:

- 12VDC or 24VDC variable speed compressor controlled by a digital ESC (electronic speed controller) allows proportional control of cooling to reduce noise and increase efficiency, short-cycling of compressor is no longer a concern;
- Unit uses industry-standard R-134A eco-friendly refrigerant;
- Low-noise, variable speed condenser and evaporator fans run very quiet;
- Unit designed for fast and adequate reaction to temperature changes for increased comfort;
- Wireless remote and on-unit segment LCD and touch panel provided for operator's convenience.

2. WORKING PRINCIPLE

2.1 Electrical Diagram

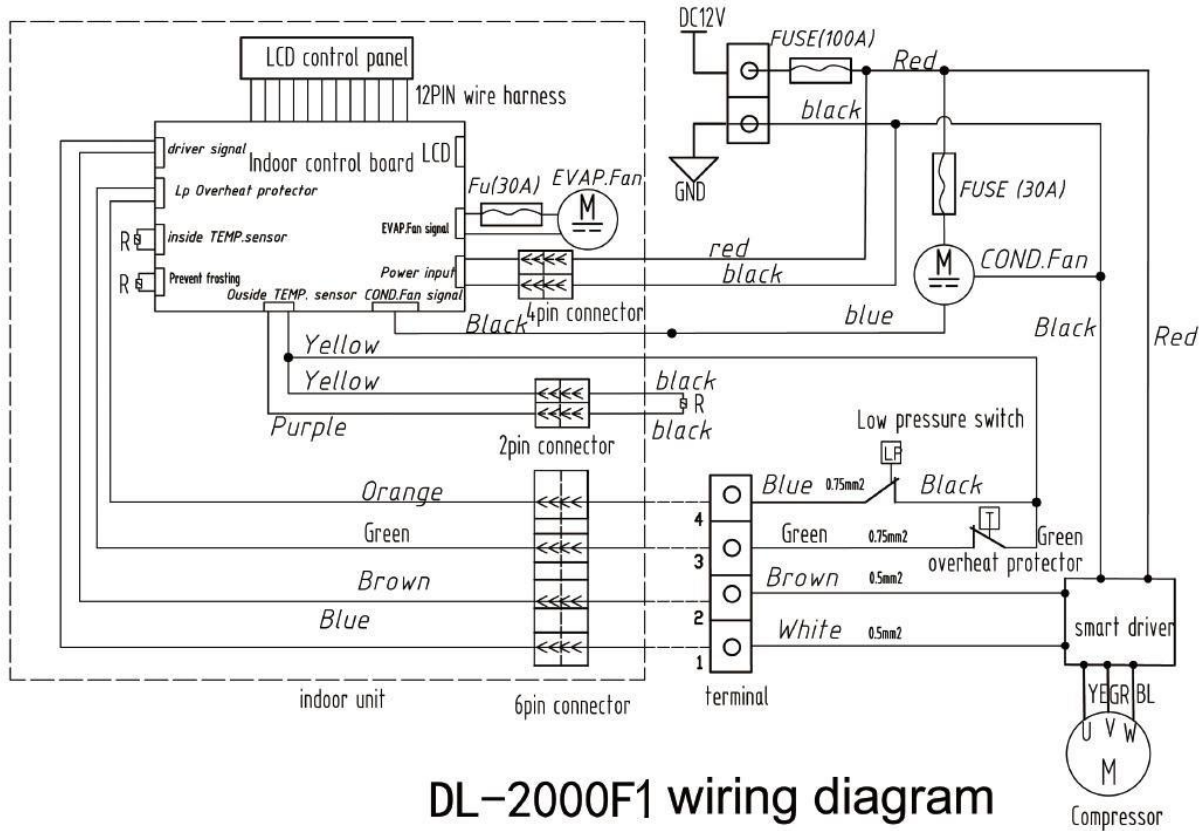

2.2 Plumbing Diagram

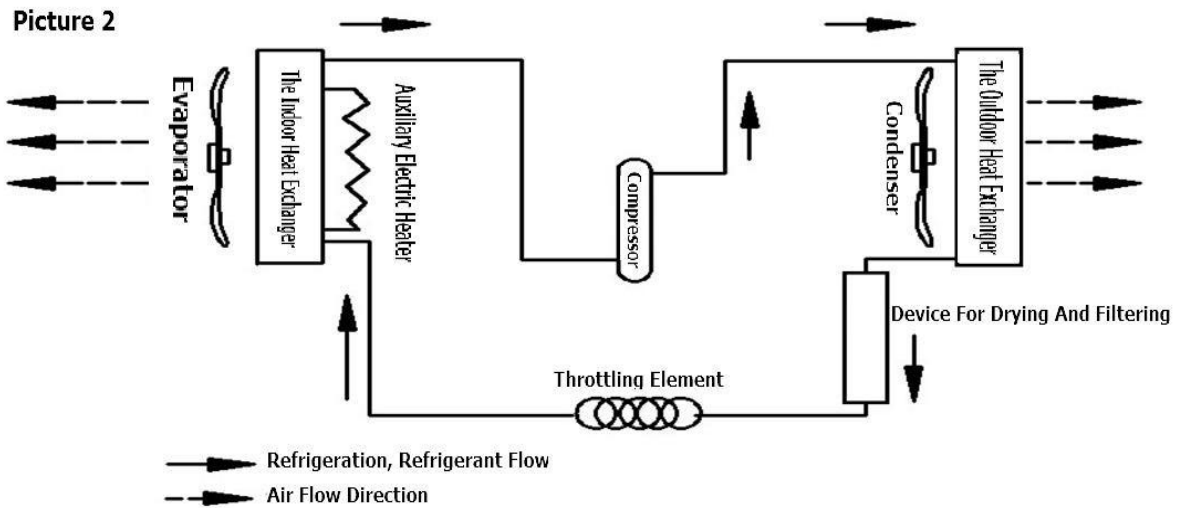

3. INSTALLATION AND COMMISSIONING

3.1 Before the install

Ease of install is one of the main pros of Lynx series AC. All refrigerant-carrying components of this kit are factory-tested for leaks and proven safe. Every kit comes pre-charged with refrigerant and contains all parts and hardware required for installation:

- Evaporator assembly (indoor unit)
- Condenser assembly (outdoor unit)
- Properly fitted and pressure-tested refrigerant lines
- Pre-terminated power and control wiring
- Mounting hardware

Unpack, identify and inspect all components of the kit before commencing install.

WARNING

- Installation of this type of equipment requires special skills in refrigeration and electrical fields, requires special tools and instruments and should be carried out only by qualified and certified personnel.**
- Do not install this product in places where combustible gas or vapor may be present.**
- Do not shorten, extend or in other ways modify factory-provided refrigerant hoses. Doing so will void the warranty and will cause equipment malfunctions.**
- Do not install refrigerant lines with signs of damage. Do not attempt to repair damaged refrigerant lines.**
- Refer to Electrical Code regulations when altering main power feed. Special consideration should be made to protect power conductors with properly sized fuse or circuit breaker at the point of connection to the APU. The AC unit itself has a built-in overcurrent protection and does not require any special considerations.**

3.2 Installation

Before mounting indoor and outdoor units, following points should be considered:

- Refrigerant line length: lines should reach both units comfortably, with some slack. Avoid strain tension on the fittings.
- Proximity to APU or other power source: outdoor unit should be located as close as practicable to the power source.
- Exposure to the elements and moving parts: provide enough clearance to prevent mechanical damage, dust, splashes of water.
- Supporting walls should be strong enough to withstand equipment weight and provide adequate grip for the mounting screws.
- Ease of access: Units should be easily accessible for service and maintenance.

3.2.1 Mounting the outdoor unit (condenser)

Remove the cover before installing the unit. Condensing unit should be mounted upright onto a flat, even surface. Unit dimensions are 681×465×192 mm (26.8" x 18.3" x 7.6"). Distance between mounting holes is 418±1mm x 505±1mm (16.46" x 19.88"). The unit is secured using M8X100 bolts provided with the kit. Recommended tightening torque is 15NM.

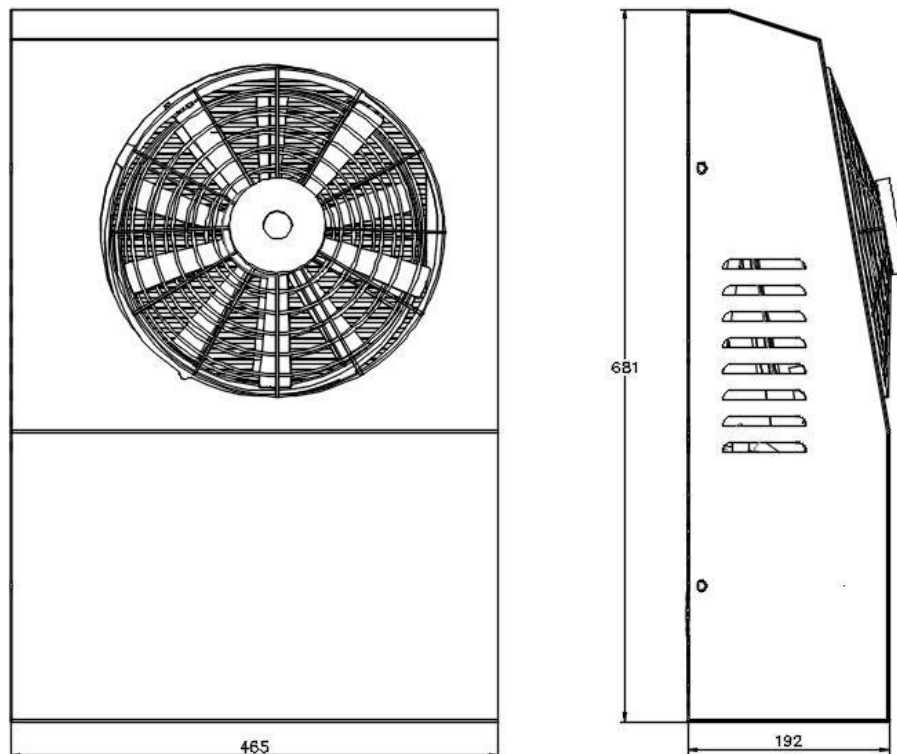

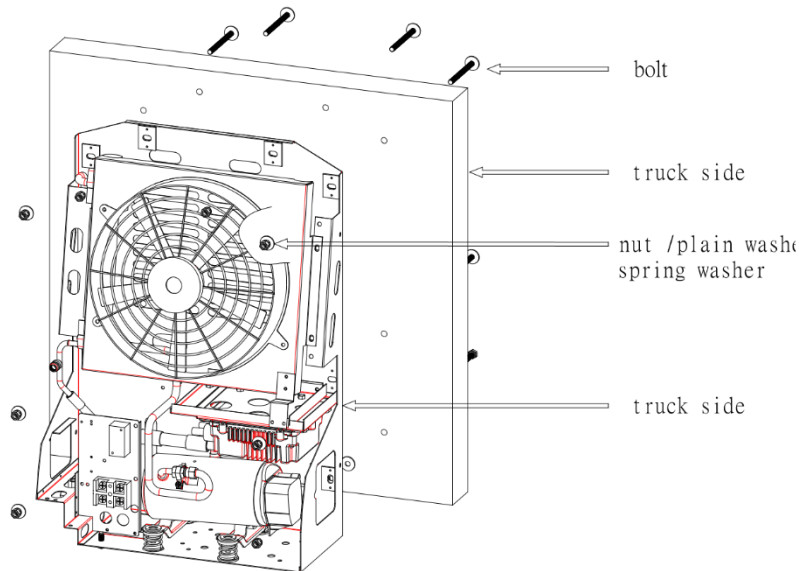

9

3.2.2 Mounting the indoor unit (evaporator)

The indoor unit need to be installed upright on the interior wall of the cabin, away from direct sunlight or cross breeze, unit controls should be easily accessible by the end user, unit should not obstruct walkways. Adequate clearance should be maintained around the unit. Special considerations should be made to allow condensate water to escape the unit without causing leaks. Please ensure the indoor unit is properly fastened.

3.2.3 Installing Refrigerant Lines

Inspect provided with the kit refrigerant lines and end fittings for signs of damage before making connection. After connecting the lines, coil excess hose, if any, and secure hose firmly to prevent friction and strain tension. Connect AC manifold gauge to the valve ports located inside the outdoor unit and use vacuum pump to remove the air from refrigerant lines. Although the leak test has been completed at the factory, it is recommended (but not necessary) to compete nitrogen leak test after the installation is complete. Alternatively, you could leave the lines overnight to make sure the vacuum is maintained within the lines. After test is complete and the air is removed from the lines – open manual valves to let refrigerant into the lines.

WARNING

- Compressor is pre-charged with the right amounts of oil and refrigerant. Do not overfill.

- When adding refrigerant to the system, do not open the high-pressure manual valve, otherwise, the AC system would force the refrigerant into refrigerant container, and push the lubricating oil out, which will damage the system.

- When adding the lubrication oil to the compressor, only 350ml of POE RB68EP oil should be used. Please use only designated oil type. Mixture of different brands of lubrication oil will form precipitates, which will affect compressor lubrication.

3.2.4 Wiring

Install and connect signal wiring between indoor and outdoor unit before connecting to power. Connect positive and negative supply conductors to the APU. Total length of supply conductors should not exceed 5 meters (15 feet). Adequate support, mechanical and thermal protection should be provided to prevent friction and consequent insulation damage. Supply conductors should be protected with properly sized fuse or circuit breaker.

3.2.5 Commissioning

After power is applied, simply run the unit as described in operating instructions. Look for abnormal noise, vibration or smell. Use manifold gauge to check refrigerant pressure throughout the cooling cycles of the unit. Let the unit run continuously at full power for at least twenty minutes. If no faults came up on the operator panel and the unit runs smooth – your installation is complete. Reinstall all covers.

4. TROUBLESHOOTING

All work on the unit should be carried out by qualified and certified individual. If unit is not performing as expected, or display is showing a fault code – stop using the unit and refer to a professional. Do not perform any work without proper tools and training.

4.1 Troubleshooting of common problems

Description of a problem	Cause	Remedy
The compressor does not start or starts and stops frequently (short cycles)	The voltage is too high or low	Bring voltage to specified voltage range
	Power supply cable is undersized	Use proper gauge supply lines
	Incorrect temperature setting	Set temperature
	Refrigerant leak in system	Repair leak and add refrigerant
Poor cooling performance	Condenser and/or evaporator coils are clogged with dust Fans or airways obstructed	Clean filter and condenser Inspect the heating exchange of the condenser
The air conditioner does not power on	The fuse in open Voltage too low The wiring or plug-in connector is not connected well	Check and replace the fuse Provide adequate voltage Verify, reseal connections
Air conditioner drains the battery faster than expected	Battery depleted or capacity is too low	Repair or upgrade the battery

4.2 Error codes and descriptions

Error Code	Error Description	Error code	Error Description
1	No error	23	TCP Error code when network is closed
2	Common software error	24	Over Temperature Protection of Compressor
3	Pointer error App control data exception	25	Low Pressure Protection
4	Logic error	26	Error finding at AT instruction in data link
5	AT Command cache full	27	Indoor temperature sensing error
6	No signal detected	28	Abnormal compressor shutdown
7	TCP Analysis busy	29	Over Input Voltage Protection, Above 15.5V
8	Server reported data error	30	Low Input Voltage Protection, Below 11V
9	AT Incomplete instructions	31	The evaporator is below -1 degree.
10	Connection server error	32	Anti-freezing Protection
11	Command sending error	33	Room Temperature Sensor Open
12	Command sending is busy	34	Room Temperature Sensor Short Circuit
13	Initializing network failed	35	Outside Temperature Sensor Open
14	Failed to read SIM card	36	Outside Temperature Sensor Short Circuit
15	Failed to open network port	37	Compressor Driver under voltage
16	Too long tcp/ip packet sent	38	Compressor Driver over voltage
17	Server busy	39	Over Temperature Protection of Compressor Driver
18	TCP/IP data send error	40	Compressor Failed to start
19	AT Buffer error	41	Compressor runs abnormally
20	Parsed app data error	42	Serial signal communication error between driver and main controller.
21	TCP/IP Incomplete data	43	Evaporator Temperature Sensor Open
22	An error occurred when TCP network shut down	44	Evaporator Temperature Sensor Short Circuit

5. OPERATION

Operation of the unit is very simple and self-explanatory. It could be done via remote control or control panel on the unit itself. When a remote key pressed, the unit should beep once to acknowledge the command.

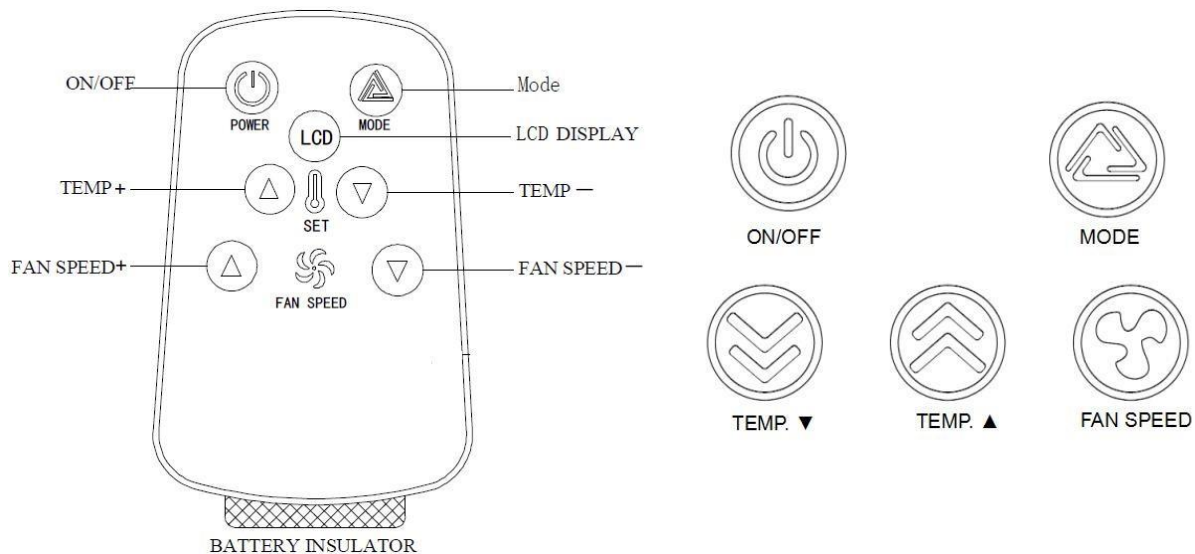

- Use **ON/OFF** power button to turn the unit on and off.
- Use **MODE** button to switch between **Cooling**, **Fan** and **Auto** modes.
- Use **TEMP ▲**(up) **▼**(down) buttons to adjust desired setpoint.
- Use FAN SPEED buttons to adjust indoor fan speed.
- Use **LCD** button to toggle between **°C** and **°F** display.

NOTE: The unit should not be operated in temperatures below +5°C or above +43°C.

6. MAINTENANCE

Regular yearly maintenance of the unit should be carried out before warm season and should consist of the following items:

- Clean condenser coil and fan from dust;
- Clean evaporator coil and fan from dust;
- Clean evaporator condensate drain from clogs;
- Inspect screws and bolts holding the units, make sure they are tight;
- Inspect wiring for frays;
- Inspect refrigerant lines and insulation for damage.

NOTE: Do not use pressure wash or sharp metal objects when cleaning evaporator and condenser coils, as this can cause fins to bend and reduce efficiency of the unit. Use compressed air and soft brush to clean the coils, do not apply force.

7. PARTS LIST